

# Energy Management Strategy Based on Frequency-Varying Filter for the Battery Supercapacitor Hybrid System of Electric Vehicles

Huang Xiaoliang<sup>1</sup>, Toshiyuki Hiramatsu<sup>2</sup>, Hori Yoichi<sup>1</sup>

<sup>1</sup>Department of Advanced Energy, Graduate School of Frontier Sciences, the University of Tokyo

<sup>2</sup>Department of Electrical Engineering, Graduate School of Engineering, the University of Tokyo  
5-1-5, Kashiwanoha, Kashiwa, Chiba, 277-8561, Japan

huang@hori.k.u-tokyo.ac.jp , hiramatsu@hflab.k.u-tokyo.ac.jp , hori@k.u-tokyo.ac.jp

---

## Abstract

Hybrid Energy Storage System (HESS), which combines the battery and supercapacitor (SC), is a potential solution for the energy system of Electric Vehicles (EV). In this paper, a battery and SC hybrid system for small-scale EV with Energy Management Strategy (EMS) and power interface design is introduced. The energy management and power sharing strategy based on frequency-varying filter method is proposed, aiming to realize both high energy density output and high power density output from HESS. The design and control aspects of the converter as the interface of SC bank are introduced. The experiment results in reduced scale test validate that the energy management strategy is effective and the converter control satisfies the requirement of HESS in our hybrid EV prototype.

*Keywords: Keywords—Supercapacitor; Hybrid Energy Management; Converter Control; Frequency-Varying Filter Approach*

---

## 1 Introduction

As an energy storage device, Supercapacitor(SC) has many advantages such as high power density, quick charging and extended lifetime. Our research focuses on the application of supercapacitor to electric vehicles. Our laboratory has already developed an EV prototype which is only powered by SC in the past year. It can be driven for 20 minutes after one time quick charging in 30 seconds [1]. However, in current stage, EV only powered by SC still has some problems such as the cost and the low energy density of SC bank.

Another solution to improve the energy system of EV, is the usage of Hybrid Energy Storage Systems (HESS), which is based on the

combination of two energy storage devices. Currently there are lots of research on HESS, including super capacitor, fuel cell and battery hybrid energy system, such as [2] and [3]. Comparing with signal energy source, HESS can provide higher performance when utilizing the advantage of each energy banks. So a lot of topics are generated here, from hybrid energy converter to the whole system optimization.

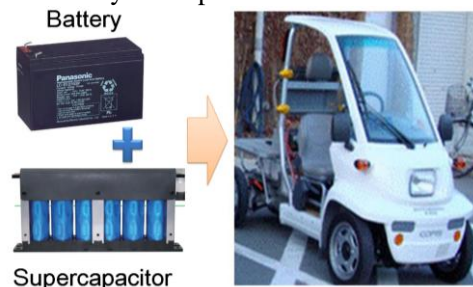

Fig. 1: battery and SC as the energy sources for EV

In another side, comparing with battery electric vehicles, the application of supercapacitor with battery has some remarkable advantages. The load stress of the battery can be released, so the battery life can be improved naturally. SC can improve the acceleration performance of EV; and enlarge the range of driven. Moreover supercapacitor is more effective during absorbing energy from regenerative braking, so the energy system efficiency can be improved. In this paper, the hybrid energy system using super capacitor and low cost lead acid batteries is considered for the design of our hybrid electric vehicle prototype. Energy Management Strategy (MES) based on frequency-varying filter method is proposed for the designed hybrid energy system. In the section 2, our hybrid electric vehicle prototype is introduced. And then the energy management strategy is analyzed in detail in the section3. The following section is the introduction of the design of the optimized dc bus converter and the control system for SC bank. At last the experiment results with a reduced scale power train system are shown. And finally the section 6 gives a conclusion of recent work.

## 2 Electric Vehicle Prototype with Battery SC Hybrid System

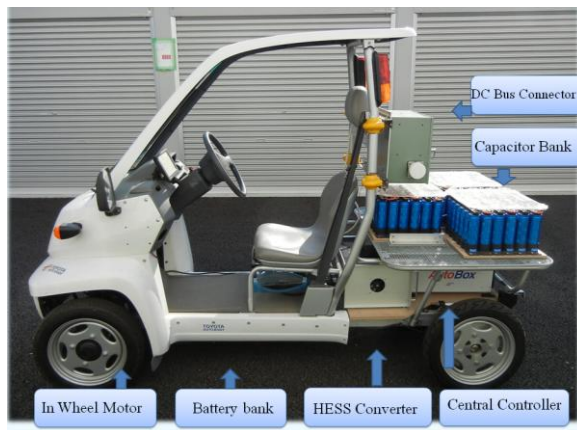

Fig. 2: Hybrid Electric Vehicle Prototype

The imagine of hybrid electric vehicle prototype for our research is given as Fig.2. The original EV is named CMOS, manufactured by Toyota Autobody.Co, Ltd. Here we set the Hybrid Energy System to this vehicle frame, as shown in Fig. 3. Firstly, the motion control ECU is added and the inverter of the two in-wheel motor is modified, in order to satisfy the requirement of vehicle advanced motion control research. For the hybrid energy system research, the energy

management processor, converter system, and the SC energy bank is set to this EV.

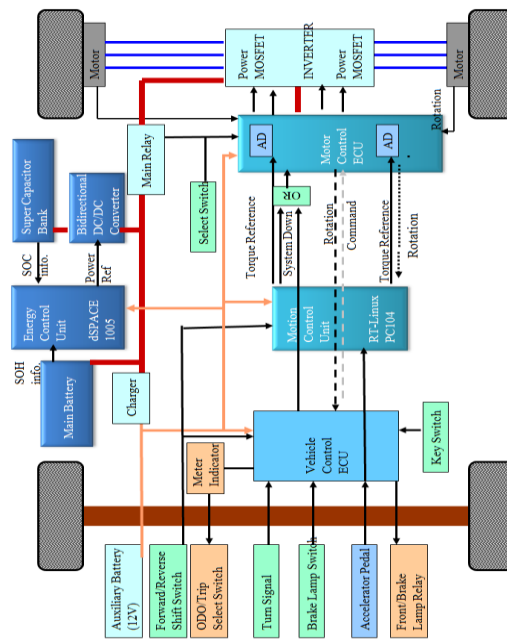

Fig. 2: System Structure of our EV with HESS

The main parameters are explained in the table.1.

Table 1, the .main parameters of Hybrid EV

EV body	Toyota Autobody COMS
In wheel Motor	Peak power 2KW X2
Max Speed	50Km/h
Weight	430Kg
DC bus Voltage	72V
Battery Bank	Lead Acid 12V 42Ah X6
SC Bank	90V 64F module X3
DC bus converter	Peak current 100A

As we designed, the HESS for this EV will be operated in different model, as below:

Normal model: SC and battery both provide energy to load following the energy management principle.

Charge model: the EV SC bank is in low SoC. The system should charge the SC form battery or from load power regeneration.

Regenerative model: the motor recover energy to energy storage device.

Error model: the SC or battery, one energy source does not work or overload happened.

So our energy management system and control principle should be designed by the four basic operation models.

### 3 Energy Management Strategy Based on Frequency-Varying Filter for HESS

#### 3.1 Three layer energy management strategy

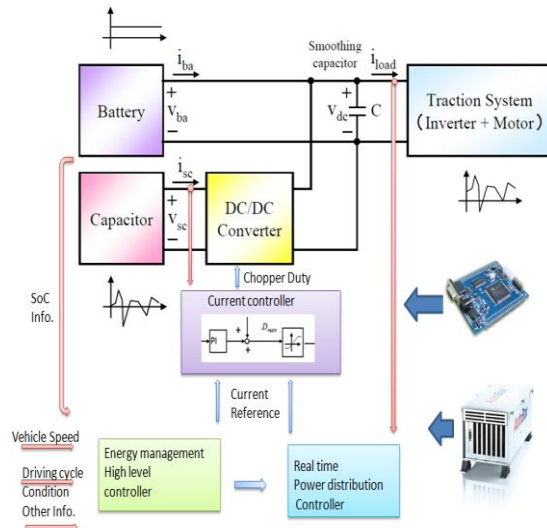

Fig3. Three layer energy management strategy

In the EMS we designed, we need the high speed power response from supercapacitor bank. Also the system should be easy to connect with vehicular information and to detect State of health of battery and State of Charge of super capacitor in real-time. More important, we need the EMS control part simple and effective.

Base on these requirements, the three-layer EMS is given here, as shown in Fig.3.

##### Chopper level controller

This section is the lowest level. The objective of this section is controlling the input/output power from SC bank to track the power reference generated by high level controller.

This section is based on the converter design and control algorithm.

##### Power sharing control

This section realizes the power distribution between the two energy banks. Here we use the frequency-varying filter method, with the consideration of driving cycle information. The objective is more effective and reasonable for using the energy from SC bank.

##### Energy State control

This section will realize the energy management function as considering the State of Charge (SoC) of the SC, load current information and the State of Health (SoH) of the battery.

Considering the sampling time of digital control

system, the lowest control loop is operated at higher than 20KHz, to realize the high speed response and good performance of the current tracking in the high frequency domain. The power sharing level works at 1KHz, to meet the requirements of the instantaneous power output for the advanced motion control of electric vehicle dynamics. The energy state control level will be the slowest. The processing can be in second class, because the objective of this level is long term optimization of HESS, and state of charge of SC and battery will be changed slowly.

In the system design, the chopper level controller can be designed together with converter system. The floating-point DSP with high speed sampling time and PWM signal output is applied in this system. For the other two layer controllers, for power sharing and energy state control, the control algorithm will be realized by dSPACE with Matlab Simulink. The advantages of this selection are that the complex advanced energy management strategy can be realized easily with Simulink for the future work, also the low level controller with DSP satisfies the high speed response with simple control algorithms.

The communication between DSP and dSPACE is realized by CAN bus, for transferring current reference signal and the state of converter state information.

#### 3.2 Frequency-Varying Filter for power sharing in realtime

Frequency decoupling method is a suitable solution for the power sharing in MES. The decoupling frequency is applied to the power distribution control. By modifying it based on different driving condition, both SC and Battery output power is changed to satisfy the requirement from the vehicle power train. The system behaviour for different driving cycles can be analysed using different decoupling frequencies.

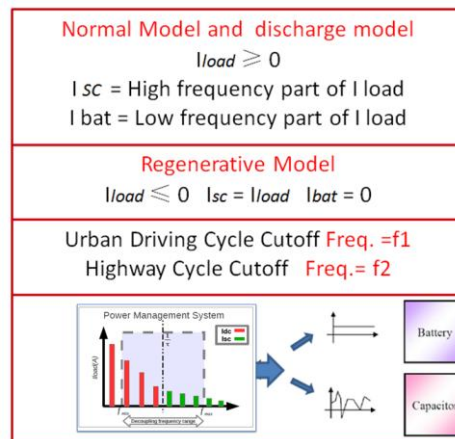

Fig. 4 Frequency-Varying Filter for Power sharing

The basic idea of power sharing method is separating the power requirement from load into two part in real-time. The high frequency part is provided by the SC bank and the low frequency part is from the battery bank. The battery stress can be release because some part of the required power is transfer to SC bank. Also peak power is remarkably decrease if the power from the battery is low frequency part. So it is positive to extend the life cycle. The principle is in the Fig.4. Also when regenerative braking, all the power is recovered to the SC bank by the current control algorithm. As we know, the efficiency of SC for peak power charging is higher than Lead Acid battery. So the efficiency of the HESS is increased by control the recover current flow.

Frequency-Varying Filter is applied in our system, so the cut-off frequency can be changed based on different driving cycle. The aim for frequency varying is maximizing the efficacy of the SC bank utilization. For example, in the urban driving cycle, we increase the cut-off frequency of the power filter. So the SC can be charged and discharged less energy every time. As we know the frequency of acceleration and deceleration cycle is high. It is good for the SC bank to provide energy assistance in a long time without returning to the Charging Mode as we mentioned in Section 2.

On the other hand, when in the highway driving cycle, there is a long distance between every acceleration and deceleration cycle. We can increase the cut-off frequency of the power filter to use the SC bank in deeply State of Charge during every speed up.

The decision of the frequency is made by the high layer controller in our system.

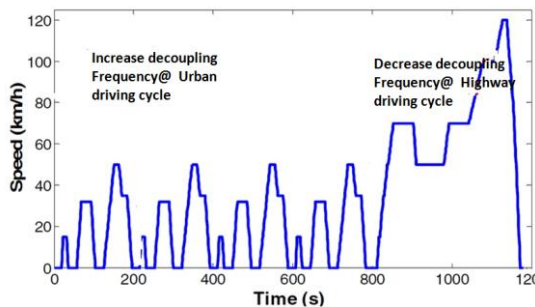

Fig 6 NEDC speed profiles from ref. [6]

For the next step, the high layer controller can identify the different driving condition, and then the decoupling frequency can be decided to optimize the consume of the whole energy system

## 4 Power Interface for SC and Converter Control

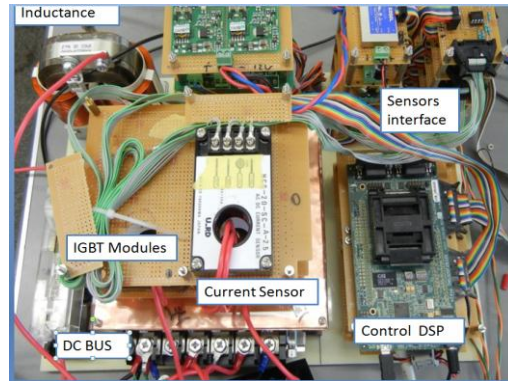

Fig.6. Converter Prototype for SC power interface

In our topology of HESS, the battery is linked directly to the DC bus, and the voltage is 72 Volt. So only one converter is needed as the power interface for the SC bank, that is enough for the whole system control. Because the DC bus voltage is hold by the battery bank. If the converter can be controlled to manage the power from the SC bank, the power from the battery bank will be controlled passively. This is the most simple and effective topology option for our HESS system.

So, for the power interface of supercapacitor bank to the DC bus, a bidirectional huge current output converter, with widely variable voltage on SC side, is needed. And for the vehicular application, the small-size structure should also be considered.

Based on our previous research, the Half Controlled converter topology for SC bank is applied here.

The advantages of HCC are remarkable. The ratio between the Volt-Ampere Ratings of the switches in the HCC can be decreased to half of the half bridge system. And the inductor of the HCC can be decreased nearly 50% [4], [5].

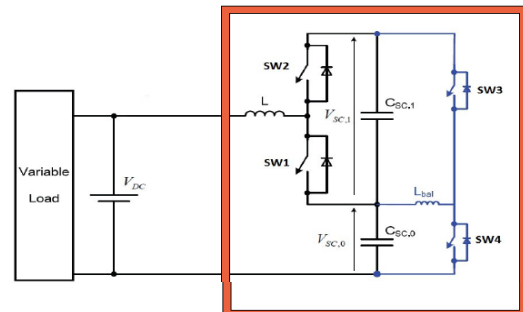

Fig.7 Half controlled converter structure for HCC

The main chopper is designed by using IGBT with 200A maximum current. And the inductance in the converter system is 0.48mH with 100A peak

current, as shown in Fig. 6. The chopper frequency is 20kHz.

The control section is not mentioned in detail in this paper. The current unit with PI and feed forward controller is set with the converter system. TI DSP28335 is used to realize the chopper level control in our MES.

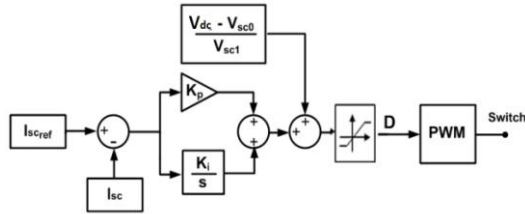

Fig. 8. Main current control loop for Half Controlled converter [7]

## 5 Experiment and Analysis

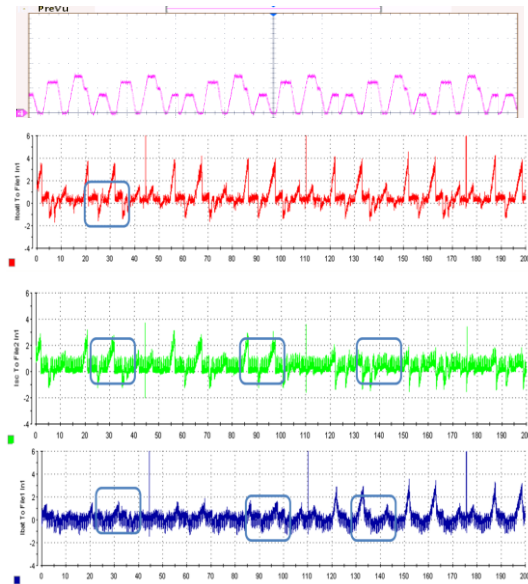

Fig.9. Experiment result in simulated urban driving cycle

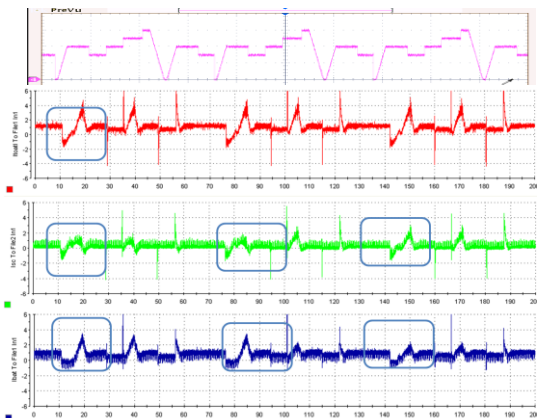

Fig.10 Experiment results in simulated highway driving cycle

The tests and experiments is realized in a reduced scale power train system before setting the HESS with converter prototype to the electric vehicle COMS. The 200 seconds simulated driving cycle is applied to test the HESS power sharing and convert control. The load and the power train system is realized by the 600w DC motor-generator system

In Fig. 9 and Fig.10, it can be seen that the power for load can be separated to two sections. High frequency part is from SC, while low frequency part from battery. All the recovered energy returns to SC bank, and it improves the energy efficiency of the whole system.

Frequency-Varying Filter Strategy can be used in different driving cycle to maximize the use of SC. The range of the cutoff frequency is from 0.01 to 1Hz. The energy from SC and battery is nearly the same in one driving cycle when the cutoff frequency is near to 0.09. And nearly 30% of the energy is recovered to SC bank in every driving cycle test.

## 6 Conclusion

The efficiency of Energy Management Strategy based on frequency-varying filter with half controlled converter is confirmed. The SCs supplies most of the transient power required by the load. The SCs' power has the fastest dynamics. The battery power has the slowest dynamics and both are well tuned. Energy is partly recovered to SC bank by regenerative braking.

As optimized interface for SC, Half Controlled topology is effective. Energy Management based on power filter strategy in deferent cutoff frequency is tested

The next step is ground test for HESS, since we have already finished the setup of the Hybrid EV. High level control strategy and SoC management strategy design based on vehicular information will be considered in the next step.

## Acknowledgments

Here we would like to thank the Nippon Chemicon Co. Ltd., who provided supercapacitor modules for our research.

## References

- [1] Kawashima, K.;Hori, Y.;Uchida,T, "Stabilizing control of vehicle motion using small EV driven by ultra-capacitor", IECON 2005., Nov 2005
- [2] Camara, M.B.; Gualous, H.; Gustin, F.; Berthon, A., "Design and New Control of DC/DC Converters to Share Energy Between Supercapacitors and Batteries in Hybrid Vehicles," Vehicular Technology, IEEE Transactions on , vol.57, no.5, Sept. 2008
- [3] Thounthong, P.; Chunkag, V.; Sethakul, P.; Davat, B.; Hinaje, M., "Comparative Study of Fuel-Cell Vehicle Hybridization with Battery or Supercapacitor Storage Device," Vehicular Technology, IEEE Transactions on, Oct. 2009
- [4] G. Guidi, "Energy Management Systems on Board of Electric Vehicles Based on Power Electronics", Doctoral theses at NTNU, 2009
- [5] G. Guidi, T.M. Undeland, Y.Hori, "An Interface Converter with Reduced VA Ratings for Battery-Supercapacitor Mixed Systems", IEEE Power Conversion Conference, PCC07, Nagoya, Japan, April 2007
- [6] Sadoun, R.; Rizoug, N.; Bartholomeus, P.; Barbedette, B.; Le Moigne, P., "Influence of the drive cycles on the sizing of hybrid storage system battery-supercapacitor supplying an electric vehicle," IECON 2011, Nov. 2011
- [7] Curti, J.M.A.; Huang, X.; Minaki, R.; Hori, Y.;"A Simplified Power Management Strategy for a Supercapacitor/Battery Hybrid Energy Storage System using the Half-Controlled Converter",IECON 2012, Oct 2012.

## Authors



Mr. Xiaoliang Huang received the B.S. degree and the M.S. degree from Jilin University, China, in 2007 and 2009. He is currently working toward the Ph.D. degree in Graduate school of Frontier Science, The University of Tokyo. His research interests include power electronics, energy system of electric vehicle, and super capacitor application.



Mr. Toshiyuki Hiramatsu received the B.S. degree from Chiba University, Japan in 2013. Currently he is a master course student in Dept. E.E., Graduate school of Engineering, The University of Tokyo. His research topic is about supercapacitor energy storage and wireless power transfer system for EV.



Dr. Yoichi Hori received B.S., M.S., and Ph.D. degrees in Electrical Engineering from the University of Tokyo, Tokyo, Japan, in 1978, 1980, and 1983, respectively. His research fields are control theory and its industrial applications to motion control, mechatronics, robotics, electric vehicles, etc.

Prof. Hori is an IEEE Fellow and an AdCom member of IES. He is a member of the Society of Instrument and Control Engineers; Robotics Society of Japan; Japan Society of Mechanical Engineers; and the Society of Automotive Engineers of Japan. He is the President of Capacitors Forum, and the Chairman of Motor Technology Symposium of Japan Management Association (JMA) and the Director on Technological Development of SAE-Japan (JSAE).

Please check the final version of this paper in **the online proceedings of EVS 27.**